

ELGIN ACADEMY

Prelim Examination 2005 / 2006

(Assessing Units 1 , 2 + Exponential/Logs & Wave Function)

MATHEMATICS Higher Grade - Paper II

Time allowed - 1 hour 30 minutes

Read Carefully

1. **Calculators may be used in this paper.**
2. Full credit will be given only where the solution contains appropriate working.
3. Answers obtained by readings from scale drawings will not receive any credit.
4. **This examination paper contains questions graded at all levels.**

FORMULAE LIST

Circle:

The equation $x^2 + y^2 + 2gx + 2fy + c = 0$ represents a circle centre $(-g, -f)$ and radius $\sqrt{g^2 + f^2 - c}$.

The equation $(x - a)^2 + (y - b)^2 = r^2$ represents a circle centre (a, b) and radius r .

Trigonometric formulae:

$$\sin(A \pm B) = \sin A \cos B \pm \cos A \sin B$$

$$\cos(A \pm B) = \cos A \cos B \mp \sin A \sin B$$

$$\sin 2A = 2 \sin A \cos A$$

$$\cos 2A = \cos^2 A - \sin^2 A$$

$$= 2 \cos^2 A - 1$$

$$= 1 - 2 \sin^2 A$$

All questions should be attempted

1. Triangle ABC has vertices A(-5,5), B(11,-3) and C(7,9).
Q(4,8) lies on AC and AM is a median of the triangle.

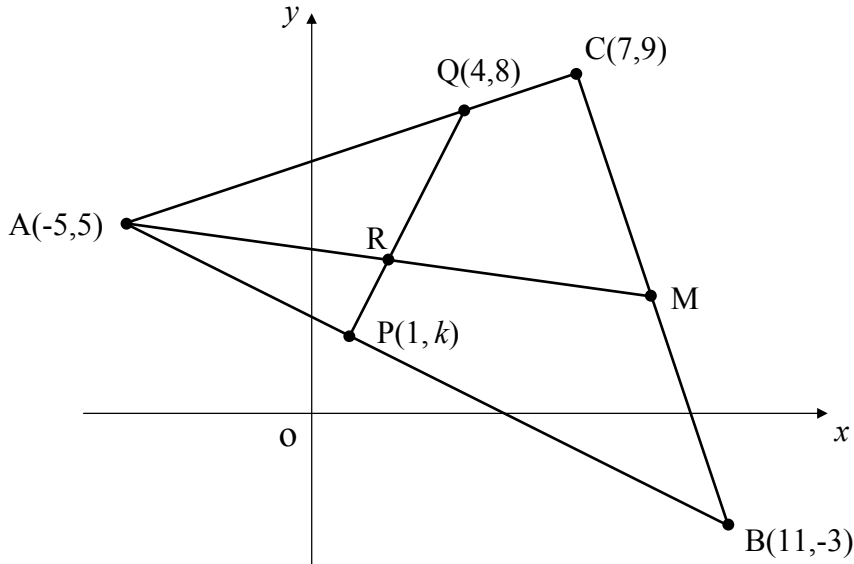

- (a) Given that A, P and B are collinear, find the value of k . 4
- (b) Hence find the equation of PQ. 2
- (c) Find the coordinates of R, the point of intersection between the line PQ and the median AM. 5
2. A scientist studying a large colony of bats in a cave has noticed that the fall in the population over a number of years has followed the recurrence relation $U_{n+1} = 0.75U_n + 200$, where n is the time in years and 200 is the average number of bats born each year during a concentrated breeding week.
- (a) He estimates the colony size at present to be 2100 bats with the breeding week just over. Calculate the estimated bat population in 4 years time immediately **before** that years breeding week. 3
- (b) The scientist knows that if in the **long term** the colony drops, at any time, below 700 individuals it is in serious trouble and will probably be unable to sustain itself. Is this colony in danger of extinction?
Explain your answer with words and appropriate working. 4

3. The diagram below shows a rectangle and an isosceles triangle. The letter p is a constant. All lengths are in centimetres.

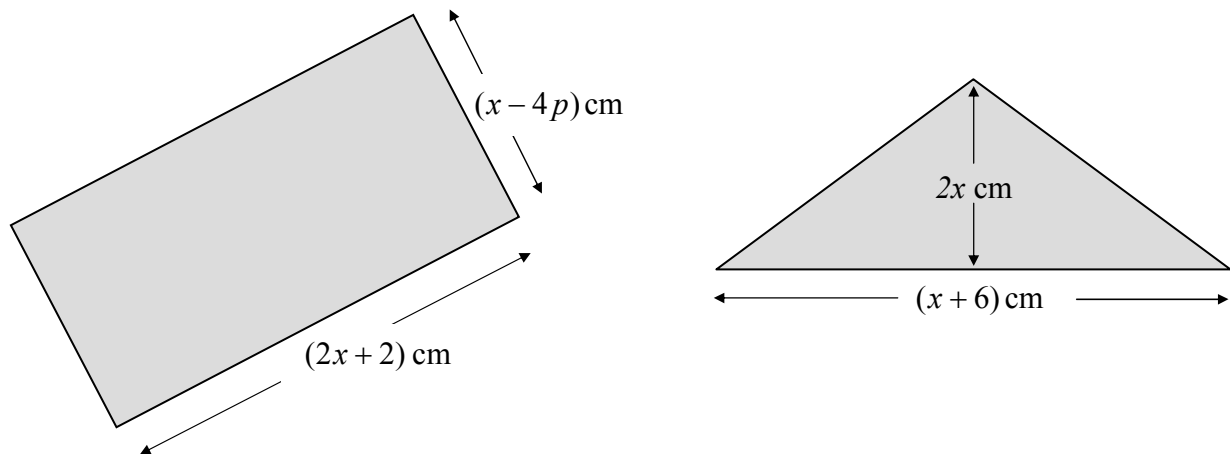

- (a) Taking A_1 as the area of the rectangle, and A_2 as the area of the triangle, show clearly that the difference between the two areas can be written in the form

$$A_1 - A_2 = x^2 - (8p + 4)x - 8p \quad 4$$

- (b) Given that $A_1 - A_2 = 1 \text{ cm}^2$, establish the value of p , where p is > -1 , for this equation to have **equal roots** for x . 6
- (c) Hence find x when p takes this value. 2

4. The diagram shows part of the graph of the curve with equation $y = \frac{x^2}{2} + \frac{8}{x}$, $x \neq 0$.

- (a) Find the coordinates of the stationary point A. 5
- (b) Also shown is the line with equation $2y = 7x - 8$ which is a tangent to the curve at B. Establish the coordinates of B. 6

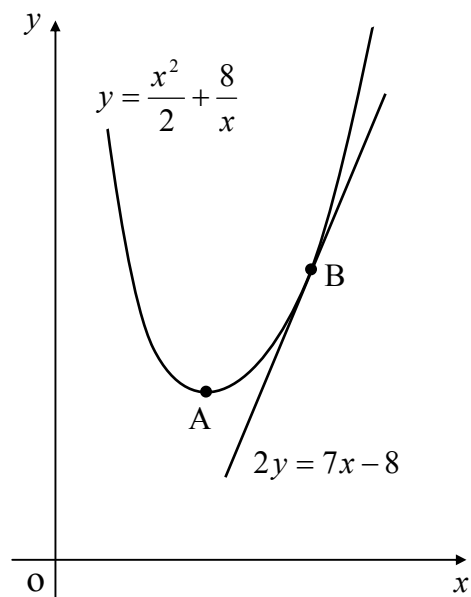

5. The diagram, which is not drawn to scale, shows part of a graph of $\log_3 p$ against $\log_3 V$. The straight line passes through the points $(0,-2)$ and $(4,0)$ as shown.

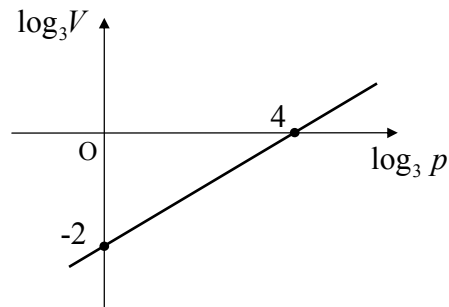

Find an equation connecting p and V .

5

6. The diagram, which is not drawn to scale, shows the cross-section of an iron bar. The units are in centimetres.

When placed in the coordinate diagram the curved section of the rod has as its equation $y = x^2 - 6x + 12$.

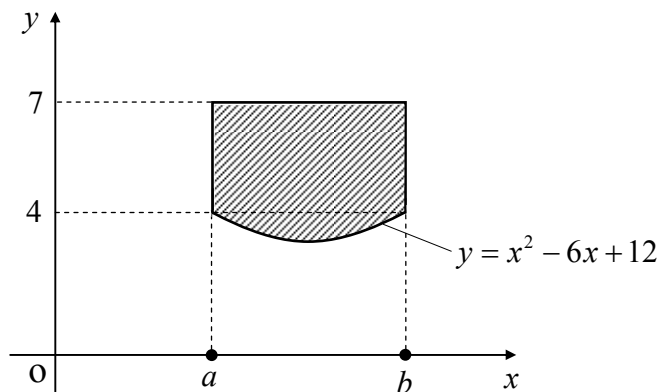

- (a) **Show algebraically** that the values of a and b are 2 and 4 respectively.

2

- (b) Calculate the shaded area in square centimetres.

6

7. Triangle PQR is isosceles with $PQ = PR$ as shown. M is the midpoint of QR. $QR = \sqrt{8}$ units, $PM = 2$ units and $\angle RPM = x$.

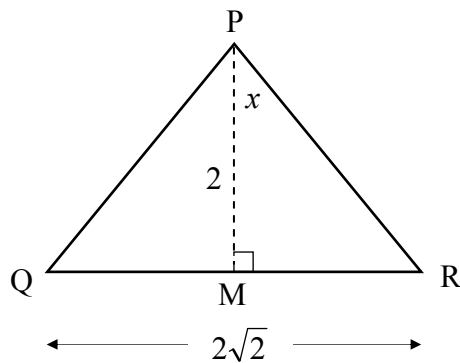

- (a) Show clearly that the exact value of $\sin x$ is $\frac{1}{\sqrt{3}}$. 4
- (b) Hence, or otherwise, show that $\sin \angle RPQ = \frac{2\sqrt{2}}{3}$. 4

8. An old fashioned bell tent is in the shape of a cone.
The tent has radius r , vertical height h and a slant height of 12 feet as shown.

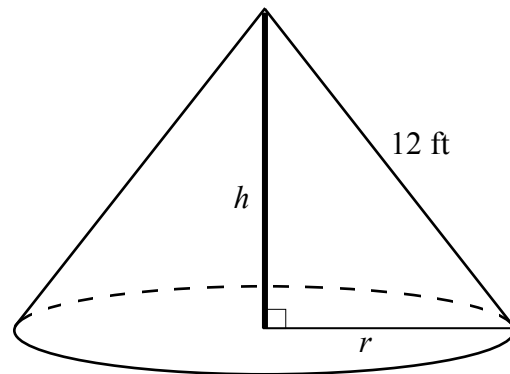

- (a) Write down an expression for r^2 in terms of h . 1
- (b) Hence show clearly that a function, in terms of h , for the volume of this cone can be expressed as

$$V(h) = 48\pi h - \frac{1}{3}\pi h^3$$

[note: the formula for the volume of a cone is $V = \frac{1}{3}\pi r^2 h$] 2

- (c) Hence find the exact value of h , the height of the tent, which would maximise the volume of the tent.
Justify your answer. 5

[END OF QUESTION PAPER]