

ELGIN ACADEMY

Prelim Examination 2008 / 09

| |
|--|
| <p>MATHEMATICS National Qualifications - Intermediate 2 Maths 1, 2 and 3 Paper 2</p> |
|--|

Time allowed - 1 hour 30 minutes

Read carefully

1. Calculators may be used in this paper.
2. Full credit will be given only where the solution contains appropriate working.
3. Square-ruled paper is provided.

FORMULAE LIST

The roots of $ax^2 + bx + c = 0$ are $x = \frac{-b \pm \sqrt{(b^2 - 4ac)}}{2a}$

Sine rule: $\frac{a}{\sin A} = \frac{b}{\sin B} = \frac{c}{\sin C}$

Cosine rule: $a^2 = b^2 + c^2 - 2bc \cos A$ or $\cos A = \frac{b^2 + c^2 - a^2}{2bc}$

Area of a triangle: $\text{Area} = \frac{1}{2} ab \sin C$

Volume of a sphere: $\text{Volume} = \frac{4}{3} \pi r^3$

Volume of a cone: $\text{Volume} = \frac{1}{3} \pi r^2 h$

Volume of a cylinder: $\text{Volume} = \pi r^2 h$

Standard deviation: $s = \sqrt{\frac{\sum (x - \bar{x})^2}{n - 1}} = \sqrt{\frac{\sum x^2 - (\sum x)^2 / n}{n - 1}}$, where n is the sample size.

All questions should be attempted

1. A patient in hospital is given 200mg of a drug at 0900. 12% of the amount of the drug at the beginning of each hour is lost, through natural body processes, by the end of that hour.

How many mg of the drug will **lost** by 1200? [4]

2. David bought 4 cream eggs and 5 flakes in a sweet shop. They cost him £3.88.

(a) Taking the cost of a cream egg to be ' x ' pence and the cost of a flake to be ' y ' pence, construct an equation in x and y to show the above information. [1]

(b) Given that Carly bought 3 cream eggs and 2 flakes and paid a total of £2.14, construct a second equation. [1]

(c) Gavin bought 2 cream eggs and a flake. How much did he pay? [4]

3. Write as a single fraction in its simplest form

$$\frac{5x}{(x-1)} - \frac{x}{5} \quad [3]$$

4. A young child was given a slab of moulding clay. It was a cuboid and measured 15.2cm by 4.8cm by 3.4cm.

(a) Calculate the volume of the cuboid rounding your answer to 2 significant figures. [1]

The clay was made into 25 identical spheres.

(b) Using your answer from part (a), calculate the radius of one of the spheres. [4]

5. P and Q are points on the circumference of a circle centre O and diameter AB.

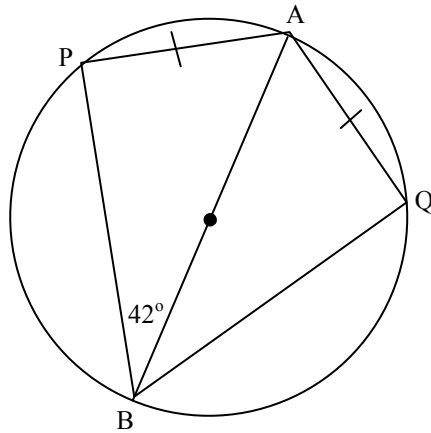

If $\angle ABP = 42^\circ$ and $AP = AQ$, calculate the size of $\angle PAQ$.

[2]

6. The frequency table shows the ages of the members of a school drama group.

| Age | Frequency | |
|-----|-----------|--|
| 11 | 7 | |
| 12 | 8 | |
| 13 | 8 | |
| 14 | 5 | |
| 15 | 3 | |
| 16 | 2 | |
| 17 | 1 | |

- (a) Copy the frequency table and add a cumulative frequency column.

[1]

- (b) Find the median age of the members.

[1]

7. Calculate the area of the sector shown in the diagram, given that it has radius 6.8cm .

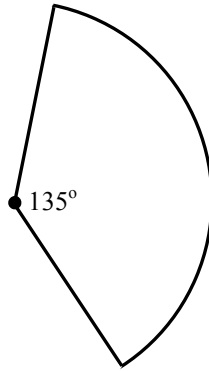

[2]

8. A selection of the number of games won and the total points gained by teams in the Scottish Premier League were plotted on this scattergraph and the line of best fit was drawn.

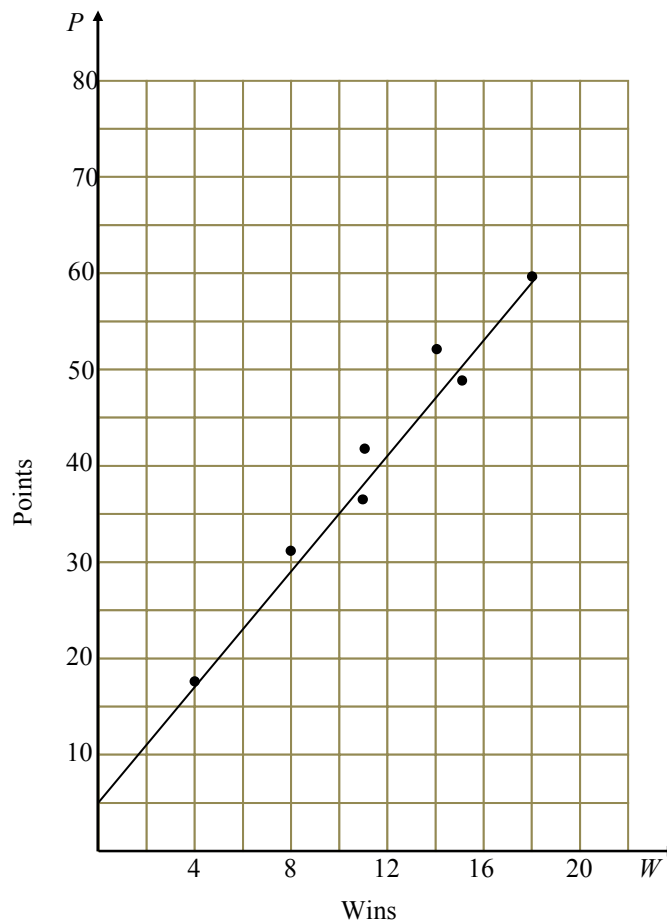

- (a) Find the equation of the line of best fit. [3]
- (b) Use your equation to calculate the points gained by a team who won 27 matches. [1]

9. An aircraft, A, is picked up by two radar stations, P and Q.

The aircraft is 60 km from station Q.

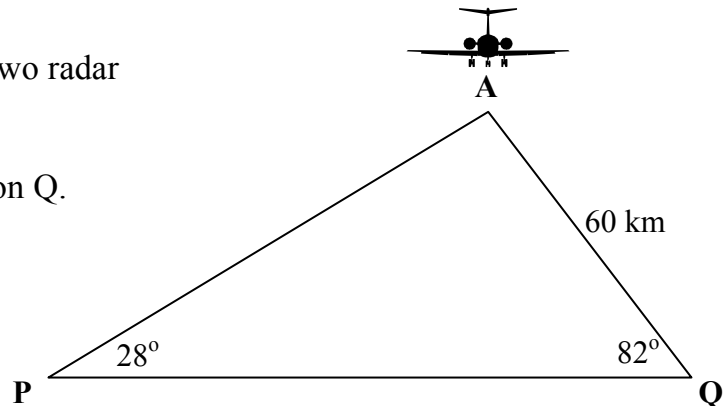

Calculate the distance between station P and station Q.

[3]

10. Find the roots of the equation $2x^2 + 3x - 7 = 0$ giving your answers correct to 1 decimal place.

[4]

11. A kitchen table is circular in shape with two 'leaves' which can be folded to save space when the table is not in use.

The table has a radius of 50cm and can be represented by a circle centre O as shown in the diagram. The table is folded along the lines AB and CD.

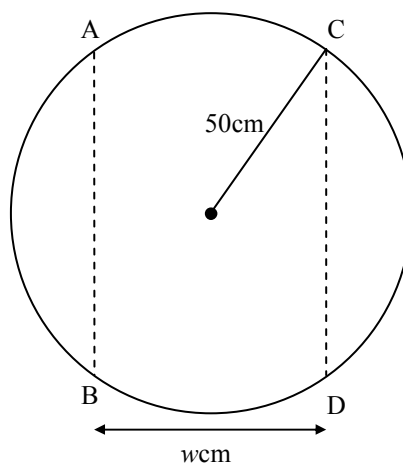

Given that $AB = CD = 80\text{cm}$, calculate the width, w cm, of the table when the 'leaves' are folded.

[4]

12. The average price of a house in thousands of pounds in different areas of the UK in 1998 is shown below. The mean is 68.5 .

61 63 54 67 109 57

Use appropriate formulae to calculate the standard deviation.

Show all your working clearly.

[3]

13. A flagpole is attached to a wall and is supported by a wire PQ as shown in the diagram.

The wire is 3.5 metres long and makes an angle of 55° with the vertical wall.

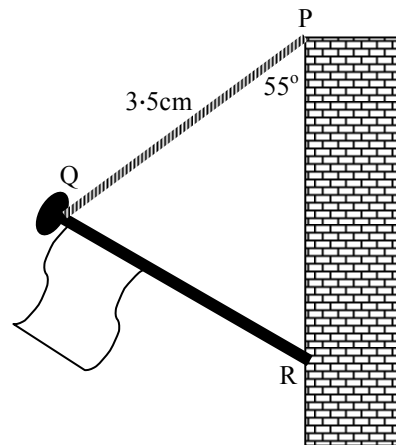

Given that the point P is 4.5 metres above R in the diagram, calculate the length of the flagpole.

[4]

14. There is an arch built over the new Wembley football stadium in London.
It can be represented on suitable axes by the parabola with equation $y = 9 - (x - 3)^2$.

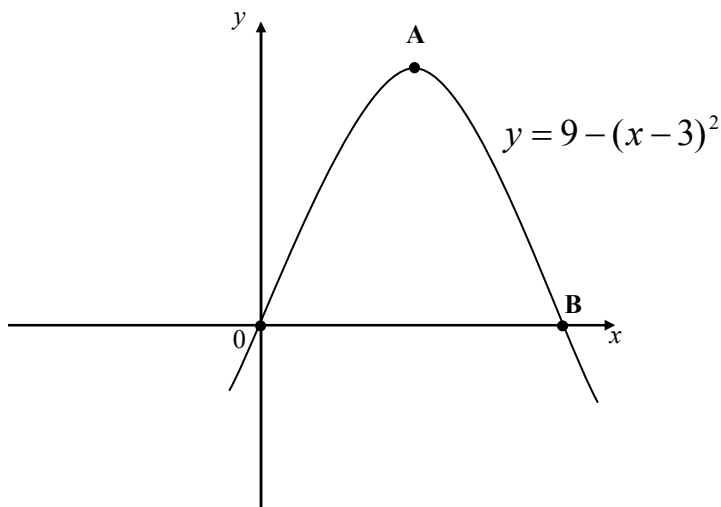

- (a) Write down the coordinates of A, the maximum turning point of the parabola. [2]
- (b) What is the equation of the axis of symmetry of the parabola? [1]
- The parabola cuts the x - axis at the origin and the point B.
- (c) Find the coordinates of B. [1]

END OF QUESTION PAPER